

INSTALLATION GUIDE	ITEM / DESCRIPTION	PART NO.	MODEL
	PATHFINDERLED® COWL LIGHT W/DRL + SEQUENTIAL	G18CWL	GL1800 / 2018 AND UP

LIST OF HARDWARE

PathFinderLED: G18CWL

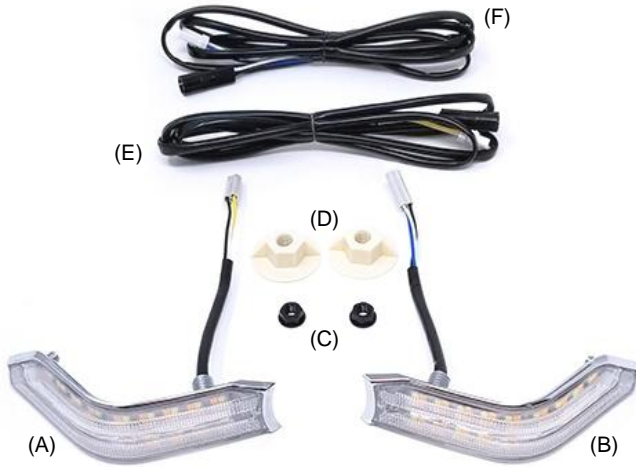

REQUIRED PARTS (sold separately)

PLUG N PLAY HARNESS ADAPTER [P/N: G184XP]



PathFinderLED P/N: G184XP

	Content Description	Qty
A	Right LED light (yellow wiring)	1
B	Left LED light (blue wiring)	1
C	Plastic 6 mm flange nut	2
D	Plastic 10 mm flange nut	2
E	Right sub harness (yellow / white / black)	1
F	Left sub harness (blue / white / black)	1
G	(1) Installation Guide & (1) Drill Hole Template	1
Digital Files Available		
Installation Guide (Online PDF printable file)		
Drill Hole Template – Right & Left side (Online PDF printable file)		

INSTALLATION NOTES:

- Perform work in a well-ventilated area.
- Place bike on the center stand.
- Disconnect the negative cable from the battery.
- Tighten the screws, bolts and nuts securely. Refer to the Honda Service Manual for the torque values of the removed parts.

NOTE: Be aware that the memory, including clock and radio, will be lost when you disconnect the negative (-) cable.

INSTALLATION TIME: ESTIMATED 2-3 HOURS

Prior to start, review this entire installation guide and installation video that is provided online

by visiting the links below:

- ▶ socialmotogear.com/g18cwlmanual
- ▶ socialmotogear.com/g18cwlvideo
- ▶ socialmotogear.com/g18cwltemplate



(PRINT TEMPLATE FILE PRIOR TO START OF INSTALLATION.)

A TEMPLATE IS INCLUDED IN THIS GUIDE. IF YOU MAKE A MISTAKE WHEN CUTTING OUT THE TEMPLATE, YOU CAN GO ONLINE TO PRINT ANOTHER ONE.

REQUIRED SUPPLIES

Wire ties, Isopropyl alcohol, Glue stick, Shop towel, Safety glasses.

REQUIRED TOOLS

Hex wrench (5 mm), Socket (8 mm), Ratchet, Phillips or JIS screwdriver, Snips, Awl, Marker, Fishwire, Scissors, Ruler, Electric drill, Drill bit (3 mm, 6 mm, and 11 mm).

WIRE HARNESS DEFINITION

White = Running

Yellow = Right turn signal

Blue = Left turn signal

Black = Ground (-)

1. Open the LEFT saddlebag lid as shown below.
 - Repeat on the right side.

LEFT side

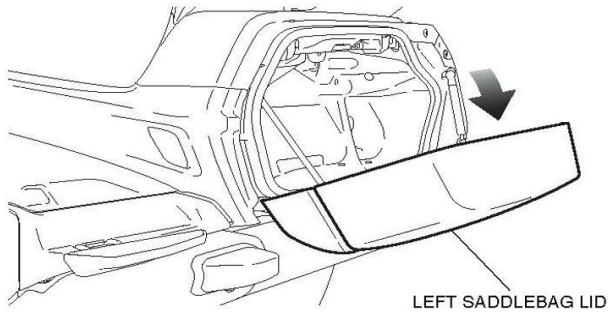

2. Remove the LEFT side cover as shown below.
Disconnect the negative (-) cable of the battery.

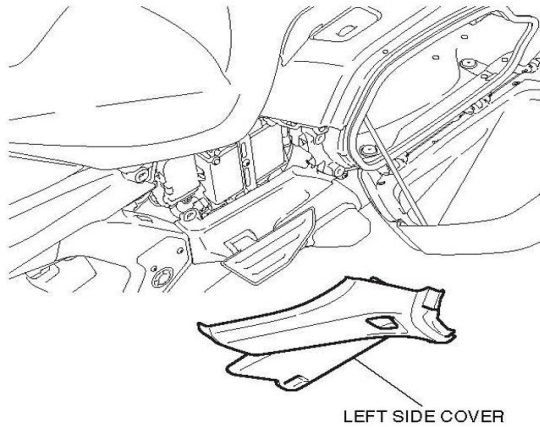

3. Remove the RIGHT side cover in the same manner as the LEFT side.

4. Remove the seat as shown below.
 - Disconnect the connector for GL1800/D/DA.

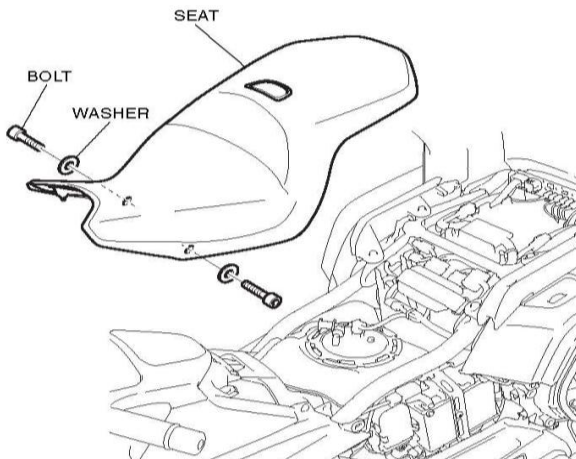

5. Remove the LEFT Fog Light cover as shown below.
 - Repeat on the right side.

LEFT side

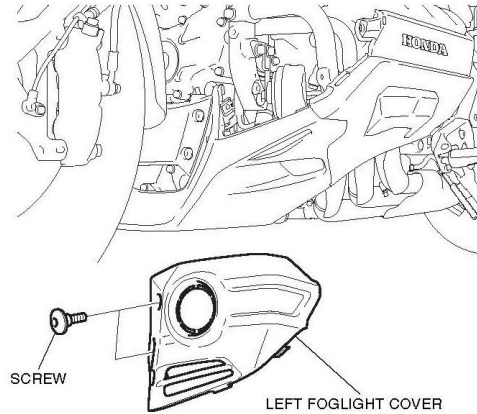

6. Clean the area of the LEFT Fog Light cover where the position light will install with isopropyl alcohol.
 - Repeat on the **RIGHT side**.

7. Use 'DRILL HOLE TEMPLATE' included/last page. Follow instructions carefully.

If needed, you can print another template to use:

www.socalmoto.com/g18cwltemplate

- Download file to print
- Do NOT select "Fit to Printable Area"
- Do NOT select "Shrink to Printable Area"
- Check the reference line (5 cm) using ruler.
[5 cm line must match the ruler's 5 centimeters mark]



8. Cut the Left and Right Templates out. Use the templates to mark the drilling locations.



The shape of MATCH POINT here is very important. Please cut it out carefully and precisely.

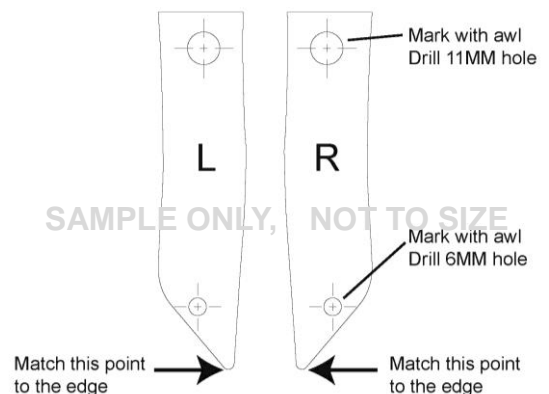

9. Apply glue (glue stick) to the back of the Right Template.

10. Position the Right Template on the RIGHT Fog Light cover by using the edge of the Fog Light cover as the guide. Match the point of the Right Template to the edge of the RIGHT Fog Light cover as shown below in Image A.

12. Drill a hole through each mark using an electric drill, starting with a 3 mm and finishing with a 6 mm and a 11 mm drill bit as shown below in Image C.

- **Remove the right template.**
- **Remove any burrs from the edge of the hole.**



11. Mark the RIGHT Fog Light cover for drilling by using an awl tool to punch through the marks on the template.

13. Fit the Right position light into place on the RIGHT Fog Light cover as shown.

- **Start with the 11 mm hole.**



14. Slightly bend the end/tail of the RIGHT Fog Light cover. Fit the bolt to the 6 mm hole as shown.



15. Tighten the plastic screws firmly **by hand**.



16. Repeat steps 9 through 15 for the left side.

17. Secure the sub harness with the wire tie to the frame as shown.

- **Route the sub harness along the inside of the frame as shown in image below.**

LEFT side

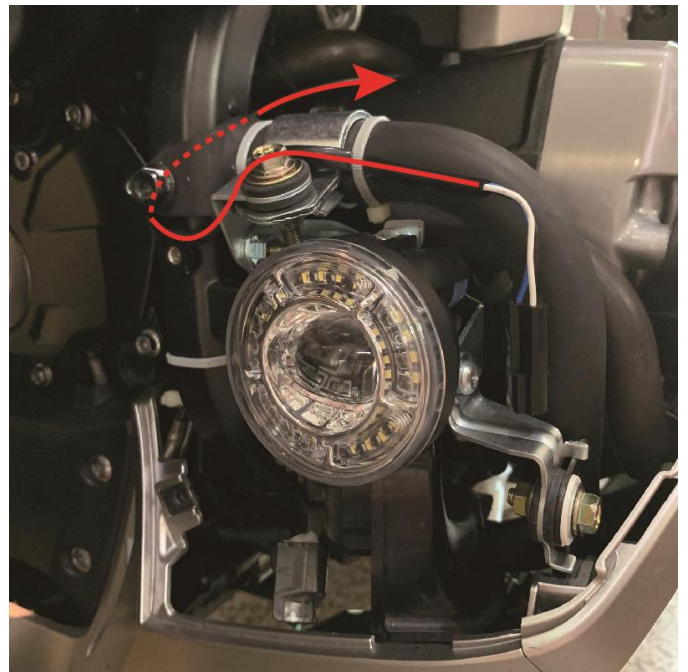

18. Use fishwire to route the sub harness through the top of the engine as shown in images below.

- Use the wire ties to secure the sub harness as needed.

LEFT side



19. Use fishwire to route the sub harness up under the seat as shown in the images below.

- Use the wire ties to secure the sub harness as needed.

LEFT side

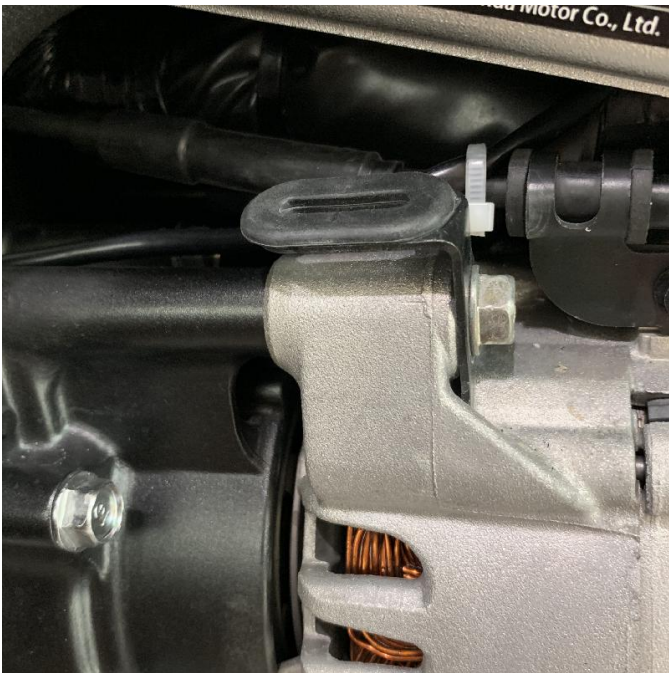

20. Connect sub harness to the Plug N Play HARNESS ADAPTER (P/N: G184XP, sold separately) as shown below.
LEFT side



21. Connect the front position light to the sub harness.
▪ **Check the foolproof connector.**
LEFT side



22. Install the Fog Light cover on the motorcycle with the front position light installed.
▪ **Confirm that the wire harness is not caught or too tight.**

LEFT side



23. Repeat steps 17 to 22 for the right side.
24. Check the front position light, headlight, and other lights for proper operation BEFORE re-assembling motorcycle.
25. Install the motorcycle's parts in the reverse order of removal.

You have completed your installation!
(Installer, please return installation guide to customer.)
=== END ===

**If you have any questions or comments,
please contact: service@SoCalMotoGear.com**